

Bellows Couplings

CL6 Series

- Zero backlash, flexible shaft
- High torque, excellent response
- Absorbs angular and parallel misalignment and shaft endplay
- Identical clockwise and counter-clockwise rotation
- Multiple bore and shaft connecting configurations



Setscrew Type



Clamp Type

CL6 OPTIONS

- Aluminum Alloy Hubs
- Stainless Steel Bellows
- Setscrew
- Clamp

ORDERING INFORMATION

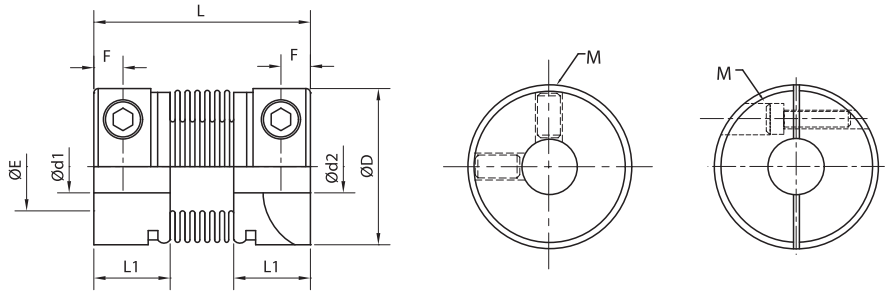
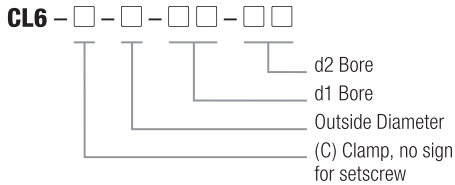

CL6 SETSCREW AND CLAMP DIMENSIONS

Model	Bore Range (Ød1-Ød2)		ØD	L		L1		ØE		F		M		Wrench Torque	
	Setscrew and Clamp			Setscrew	Clamp	Setscrew	Clamp	Setscrew	Clamp	Setscrew	Clamp	Setscrew	Clamp	Setscrew	Clamp
	in	mm	mm	mm	mm	mm	mm	mm	mm	mm	mm	metric	metric	Nm	Nm
CL6-16	0.15-0.31	4-8	16	27	30	8.5	10.5	9.5	9.5	3	4	M3	M3	0.7	0.7
CL6-20	0.23-0.47	6-12	20	29	33	8.5	10.5	12.5	12.5	3	4	M3	M3	0.7	0.7
CL6-25	0.23-0.47	6-12	25	34	38	10.5	12.5	15	15	4	5	M4	M4	1.7	1.7
CL6-32	0.31-0.55	8-14	32	38	43	11.5	14	21	21	4	6	M4	M4	1.7	1.7
CL6-32L	0.31-0.55	8-14	32	49	54	11.5	14	21	21	4	6	M4	M4	1.7	1.7
CL6-40	0.39-0.62	10-16	40	51	62	12.5	21.5	27	27	4.5	6.5	M5	M5	4	4
CL6-55	0.47-0.74	12-19	55	57	72	13.5	23	40	40	5	7	M6	M6	7	8
CL6-C65	0.70-1.49	18-38	65	N/A	81	N/A	25.5	N/A	45	N/A	9	N/A	M8	N/A	15
CL6-C82	0.78-1.65	20-42	82	N/A	103	N/A	34.5	N/A	56	N/A	11	N/A	M10	N/A	28

CL6 SETSCREW AND CLAMP SPECIFICATIONS

Model	Rated Torque		Max. Torque		Max. Speed (rpm)		Moment of Inertia	Static Torsional Stiffness	Errors of Eccentricity	Errors of Shaft Angularity	Errors of Shaft Endplay	Mass (g)	
	lb-in	Nm	lb-in	Nm	Setscrew	Clamp						kg·m ²	Nm/rad
CL6-16	7.08	0.8	14.16	1.6	20000	18000	3.4x10 ⁻⁷	100	0.1	1.5	+0.3/-1.0	8	8
CL6-20	13.27	1.5	26.54	3.0	15000	13000	8.9x10 ⁻⁷	160	0.1	1.5	+0.3/-1.0	12	14
CL6-25	17.70	2.0	35.40	4.0	13000	11000	2.8x10 ⁻⁶	220	0.15	2	+0.5/-1.3	28	32
CL6-32	22.12	2.5	44.24	5.0	10000	10000	8.8x10 ⁻⁶	310	0.2	2	+0.5/-1.3	46	52
CL6-32L	22.12	2.5	44.24	5.0	10000	10000	8.9x10 ⁻⁶	310	0.2	2	+0.5/-1.3	52	58
CL6-40	88.50	10.0	177.00	20.0	8000	8000	1.5x10 ⁻⁵	520	0.2	2	+0.7/-1.5	88	98
CL6-55	221.20	25.0	442.40	50.0	6000	6000	2.3x10 ⁻⁵	850	0.2	2	+0.7/-1.5	180	200
CL6-C65	531.00	60.0	1062.00	120.0	N/A	4500	2.8x10 ⁻⁵	960	0.2	2	+0.7/-1.5	N/A	350
CL6-C82	708.00	80.0	1416.00	160.0	N/A	4000	6.0x10 ⁻⁵	1290	0.2	2	+0.7/-1.5	N/A	750



Stainless Steel

CL14 OPTIONS

Stainless Steel Hubs
Stainless Steel Bellows
Locking Assembly

ORDERING INFORMATION

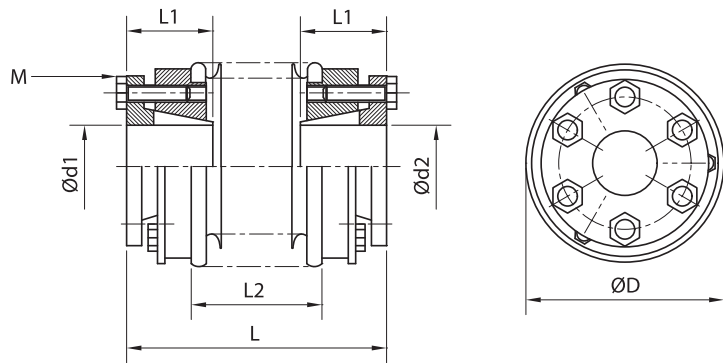
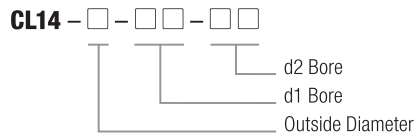

CL14 LOCKING ASSEMBLY DIMENSIONS

Model	Bore Range (Ød1-Ød2)		ØD	L	L1	L2	M	Wrench Torque
	Locking Assembly							
	in	mm						
CL14-40	0.39-0.63	10-16	40	55	19	24	M4	3
CL14-55	0.43-0.78	11-20	55	65	22	31	M4	6
CL14-65	0.55-1.10	14-28	65	76	27	37	M5	8
CL14-82	0.74-1.49	19-38	82	88	32	41	M5	10

CL14 LOCKING ASSEMBLY SPECIFICATIONS

Model	Rated Torque		Max. Torque		Max. Speed	Moment of Inertia	Static Torsional Stiffness	Errors of Eccentricity	Errors of Shaft Angularity	Errors of Shaft Endplay	Mass
	lb-in	Nm	lb-in	Nm							
CL14-40	132.80	15.0	265.50	30.0	8000	9x10 ⁻⁵	1.5x10 ⁴	0.15	2	1	210
CL14-55	265.50	30.0	531.00	60.0	6000	2.9x10 ⁻⁴	3.5x10 ⁴	0.2	2	1.5	400
CL14-65	531.00	60.0	1062.00	120.0	5000	4.6x10 ⁻⁴	6.8x10 ⁴	0.25	2	1.5	790
CL14-82	1062.00	120.0	2124.00	240.0	4500	1.1x10 ⁻³	1.2x10 ⁵	0.28	2	1.5	1210