

Curved-tooth gear coupling

Compact and maintenance-free

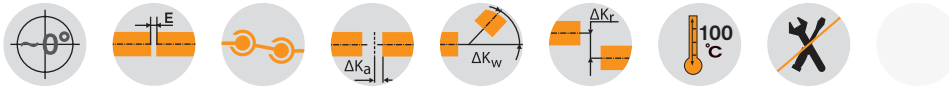

Components

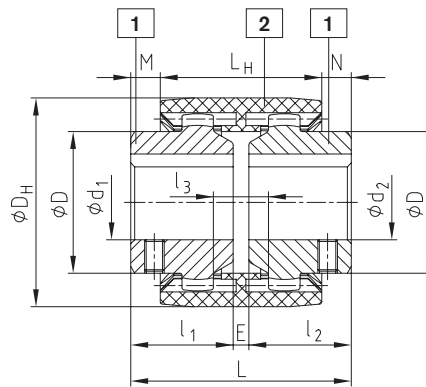

Type M

Size	Finish bore d1, d2		Dimensions [mm]											Weight with max. bore Ø			Mass moment of inertia J with max. bore Ø		
	Pilot bored	max.	l ₁ , l ₂	E	L	L _H	M, N	l ₃	D	D _H	Tip circle Ø DZ hub	Number of teeth	Hub length. l ₁ , l ₂ max.	Sleeve [kg]	Hub [kg]	Total [kg]	Sleeve [kgcm ²]	Hub [kgcm ²]	Total [kgcm ²]
M-14	-	15	23	4	50	37	6,5	10	25	40	33	20	40	0,03	0,07	0,10	0,08	0,09	0,26
M-19	-	20	25	4	54	37	8,5	10	32	47	39	24	40	0,03	0,10	0,23	0,15	0,16	0,47
M-24	-	24	26	4	56	41	7,5	14	36	53	45	28	50	0,04	0,14	0,32	0,21	0,36	0,93
M-28	-	28	40	4	84	46	19	13	44	65	54	34	55	0,08	0,33	0,74	0,65	1,22	3,09
M-32	-	32	40	4	84	48	18	13	50	75	63	40	55	0,09	0,43	0,95	1,14	2,17	5,48
M-38	-	38	40	4	84	48	18	13	58	83	69	44	60	0,13	0,55	1,23	1,58	3,55	8,68
M-42	-	42	42	4	88	50	19	13	65	92	78	50	60	0,14	0,68	1,50	2,32	5,98	14,28
M-48	-	48	50	4	104	50	27	13	68	95	78	50	60	0,23	0,79	1,81	3,90	7,22	18,34
M-55	-	55	52	4	108	58	25	14	82	114	95	45	65	0,35	1,28	2,91	10,1	18,6	47,2
M-65	21	65	55	4	114	68	23	16	96	132	110	42	70	0,55	1,90	4,35	21,2	31,8	84,8

Ordering example:	M-28	d ₁ Ø20	d ₂ Ø28
	Size and type of coupling	Finish bore H7 keyway to DIN 6885 sheet 1 (JS9)	Finish bore H7 keyway to DIN 6885 sheet 1 (JS9)